



# GRAFORM

Tool Maker and Plastic Part Production

1986

# Plants

## Bydgoszcz

Headquarter Toolshop



## Kruszyn

Production facility – Injection & Blowmolding



**1986**

Establishment of company – injection molding

**1988**

Establishment of Toolshop

**1993**

Transfer to current location

**1995**

First project with automotive industry

**2012**

Start of production in the new location

**2010**

Start of building the new location (Kruszyn)

**2007**

ISO/TS 16949 certification

**2000**

ISO 9001 certification

*Almost 40 years of experience*

# Total Workforce:

# 250 Employees

- ✓ Wayman – Project management software
- ✓ Online human capacity calculation
- ✓ Online tool shop capacity calculation
- ✓ Real-time project progress tracking

- ✓ Comprehensive planning from purchase order to full customer acceptance
- ✓ Detailed planning across all milestones
- ✓ Qualified staff with expertise in automotive industry requirements
- ✓ In-depth knowledge of the PPAP product approval process
- ✓ Certified PRINCE2 project managers

Expert Professionals Committed to Delivering the Perfect Product for You

# GRAFORM

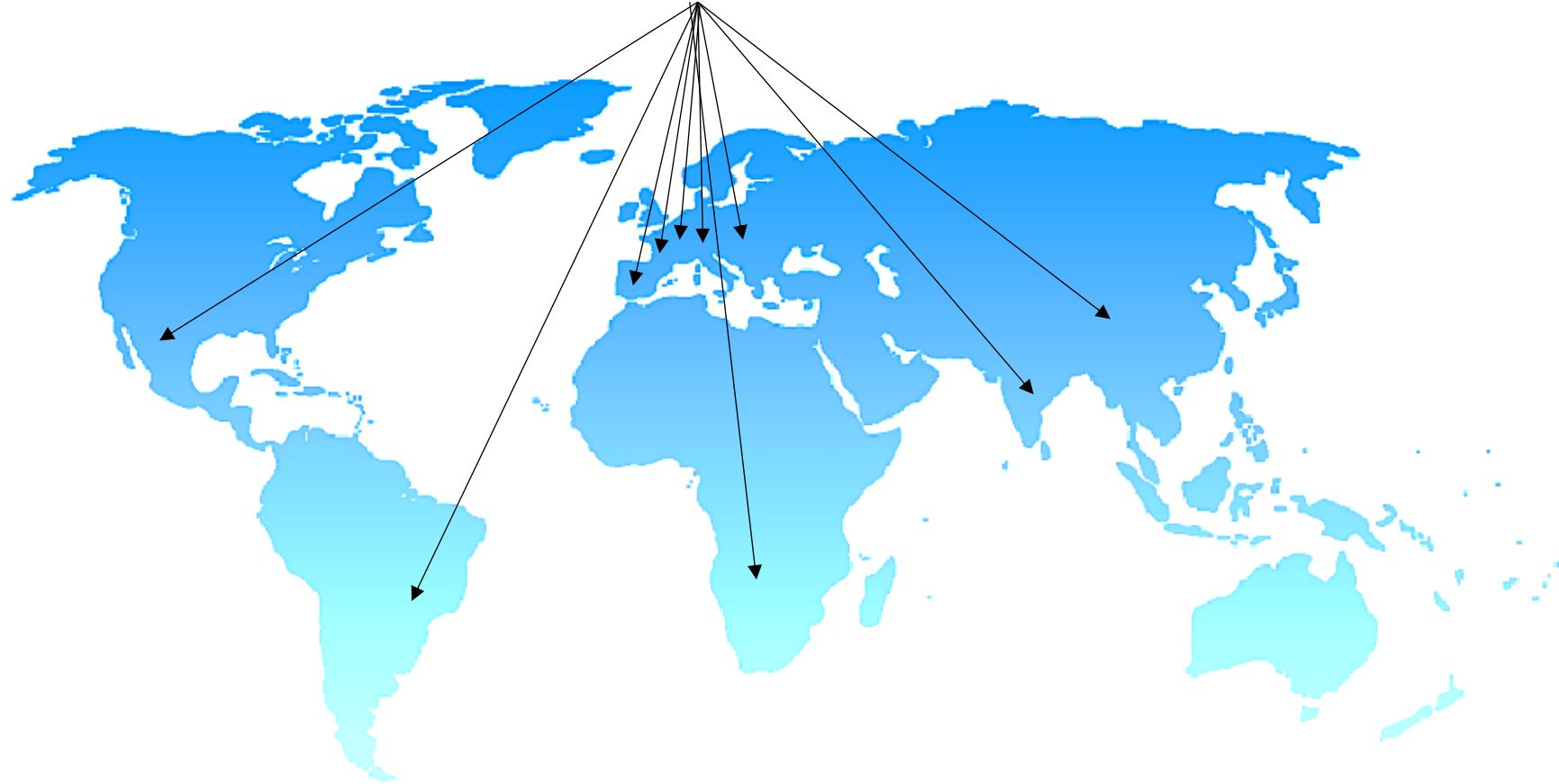

## We serve customers worldwide

Germany – France – United Kingdom – Mexico – Brazil – Africa – Hungary – Czech Republic –  
Sweden – India – China – Poland

# Company Structure



1

## Designers



- 6 Designer Workstations (5 NX + 1 CATIA) + External Designers
- 5 CNC Programmers
- Comprehensive 3D Mold Design
- File Compatibility in Any Format
- Moldflow Analysis Station (CADMOLD)

3

## Quality Department



### Fully Equipped Laboratory, including:

- 3D Measuring Machines,
- Optical Measuring Machine
- 3D Balancing Machine
- Thermal Imaging Camera
- Altimeters: Mitutoyo
- Measuring Microscope
- VISION Hawk
- Gloss Measurement : NOVO-GLOSSFull



## Toolshop 2

### 36 machines for:

- Grinding
- Milling
- Lathing
- EDM (Electrical Discharge Machining)
- Wire Cutting
- Drilling
- Welding





## **Production Areas:**

- Bydgoszcz – 7,200 m<sup>2</sup>
- Kruszyn – 7,500 m<sup>2</sup>

## **Machines:**

- 38 injection molding machines (25–900T)
- 3 blow molding machines

# Automotive Injection Molding Production

- Interior Components (Visual & Structure)
- Engine Cooling Components
- Exterior & Functional Parts

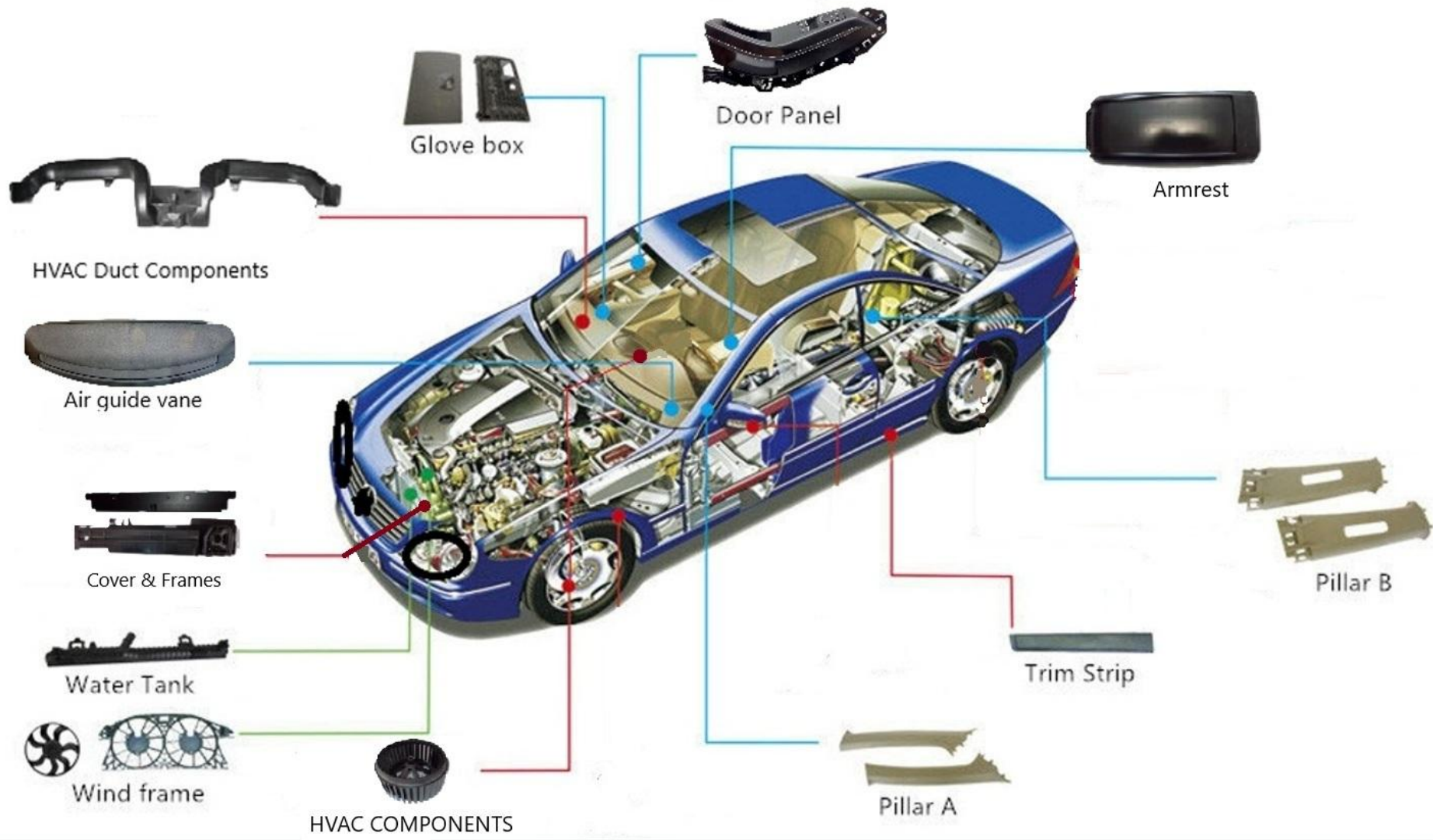

- Water cooler**
- Water Tanks
  - Frames
  - Covers

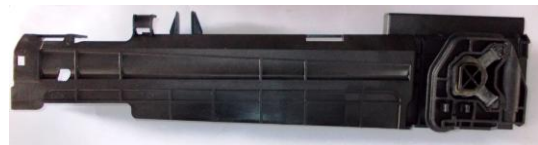

- Air cooler**
- Shrouds
  - Fans



### HVAC Components

- HVAC Fan components



### Instrument Panel Components

- Glove Box Lid
- Non Knee Airback
- Concealing panel
- Air Defrost Inlet



### Console Components

- Armrests

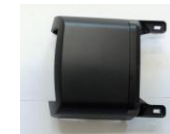

# Electrotechnical Parts



• We are specializing in the precise manufacturing of household appliance connectors, including full assembly. Our capabilities cover the entire process, from production to final assembly, ensuring high-quality and reliable components tailored to our customers' needs.

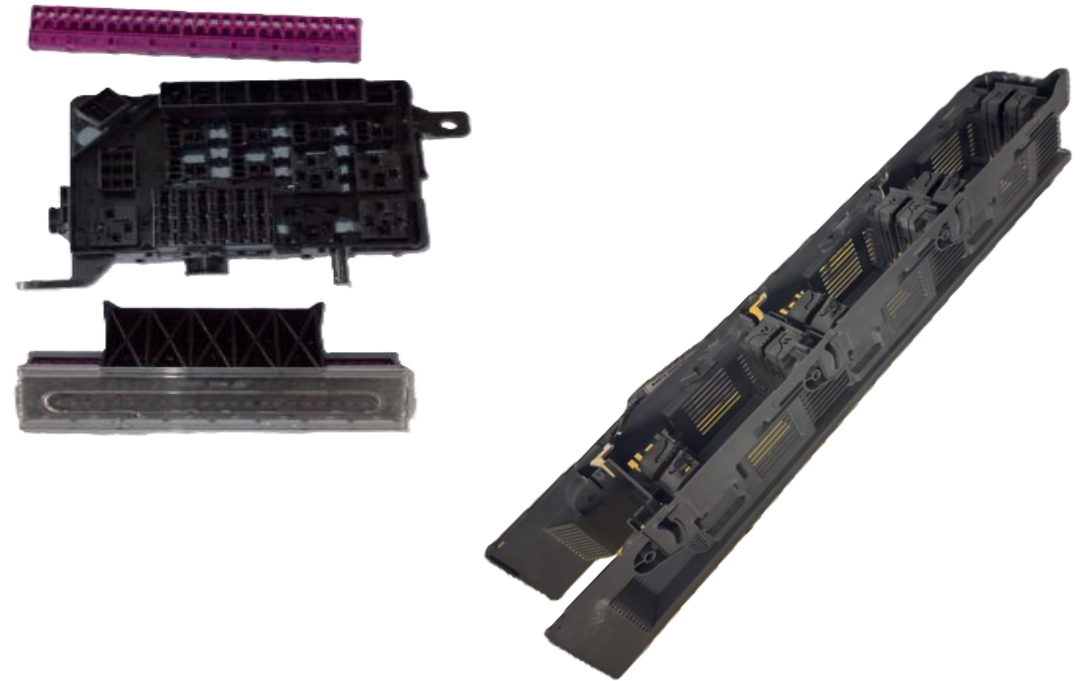

# Blow molding – Plant Graform Kruszyn

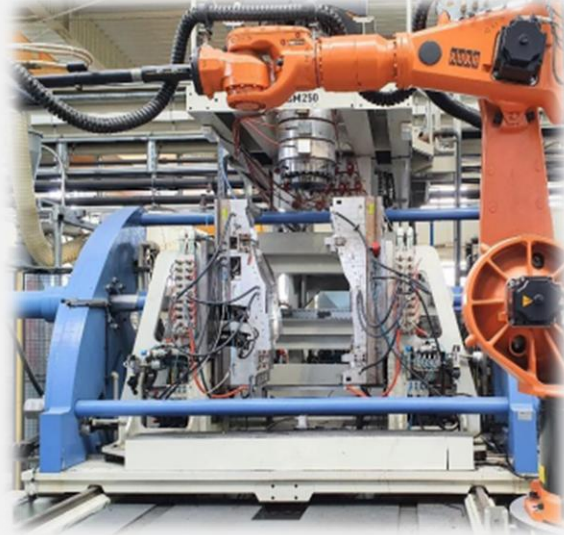

# Microcellular Technology – Mucell

**Mucell technology** works by injecting tiny gas bubbles into plastic or other materials during production. This creates a foam-like structure inside the material, making it lighter while maintaining strength. The process helps reduce weight, save material, and improve performance, all while keeping the material's surface smooth.

**Reduced Cycle Time,  
Increased Capacity**

**Lower Warpage, Higher  
Dimensional Stability**

**Weight Reduction &  
Optimized Density**

**Enhanced Material  
Efficiency**

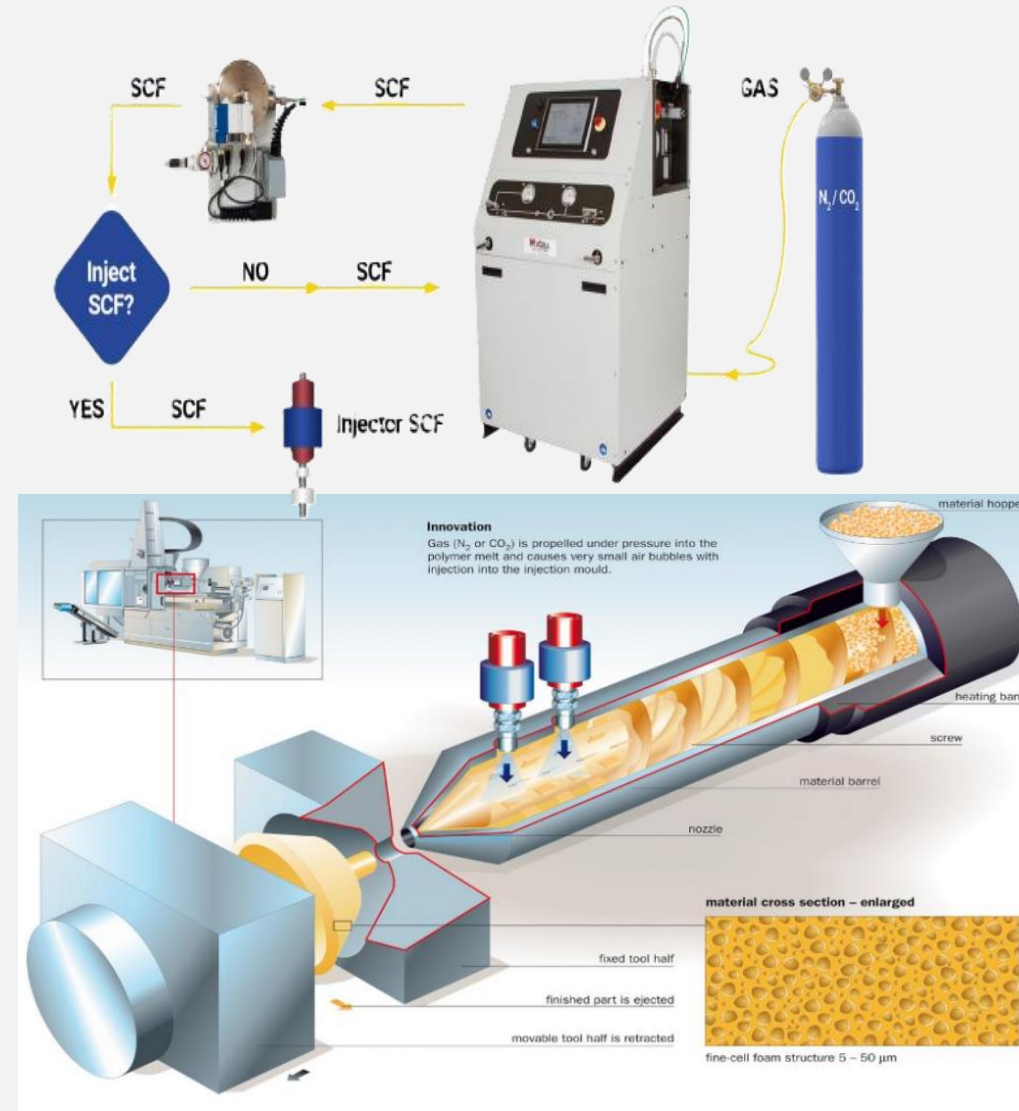

# Automation of Manufacturing Operations

- Design and manufacturing of automated assembly lines and robots for both internal and external production.
- Design and manufacturing of semi-automatic assembly lines and automated gauges for both internal and external production.

A dedicated in-house team responsible for automation manufacturing and maintenance.

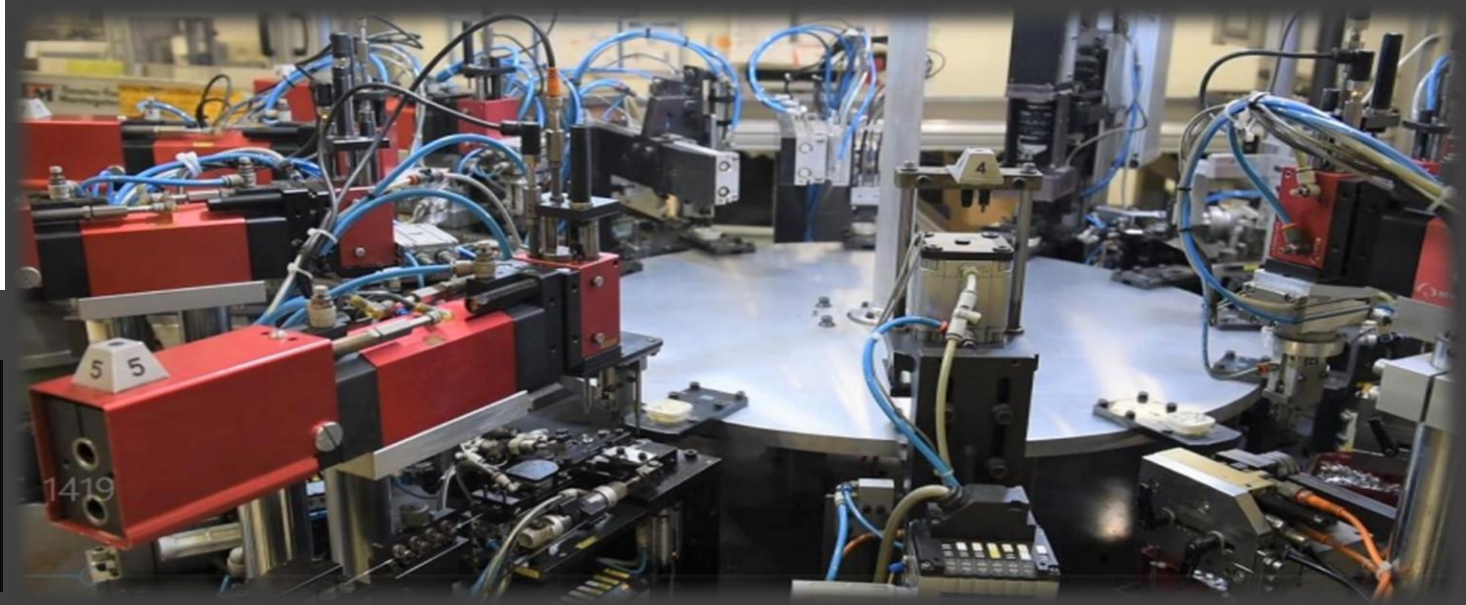
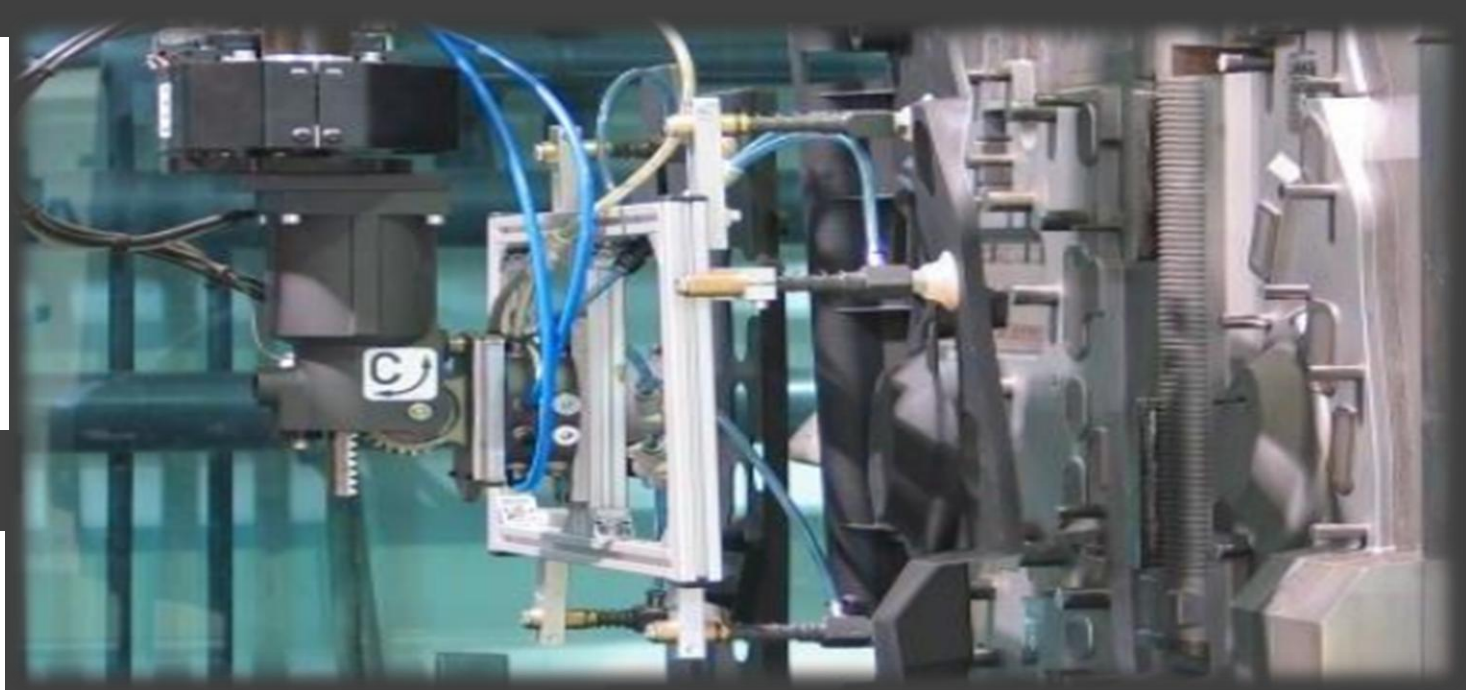

# Customers

**Valeo**

**MAHLE**

**signify**

**FORVIA**  
Inspiring mobility



**BOSCH**

**ECOWATER**  
SYSTEMS

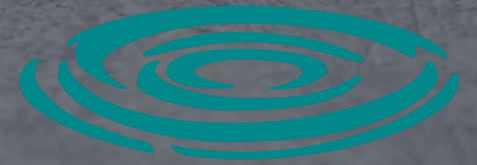

**APATOR**  
POWOGAZ

**TITANX**

**THULE**  
SWEDEN

**sapa:**

# CUSTOMERS IN 2025

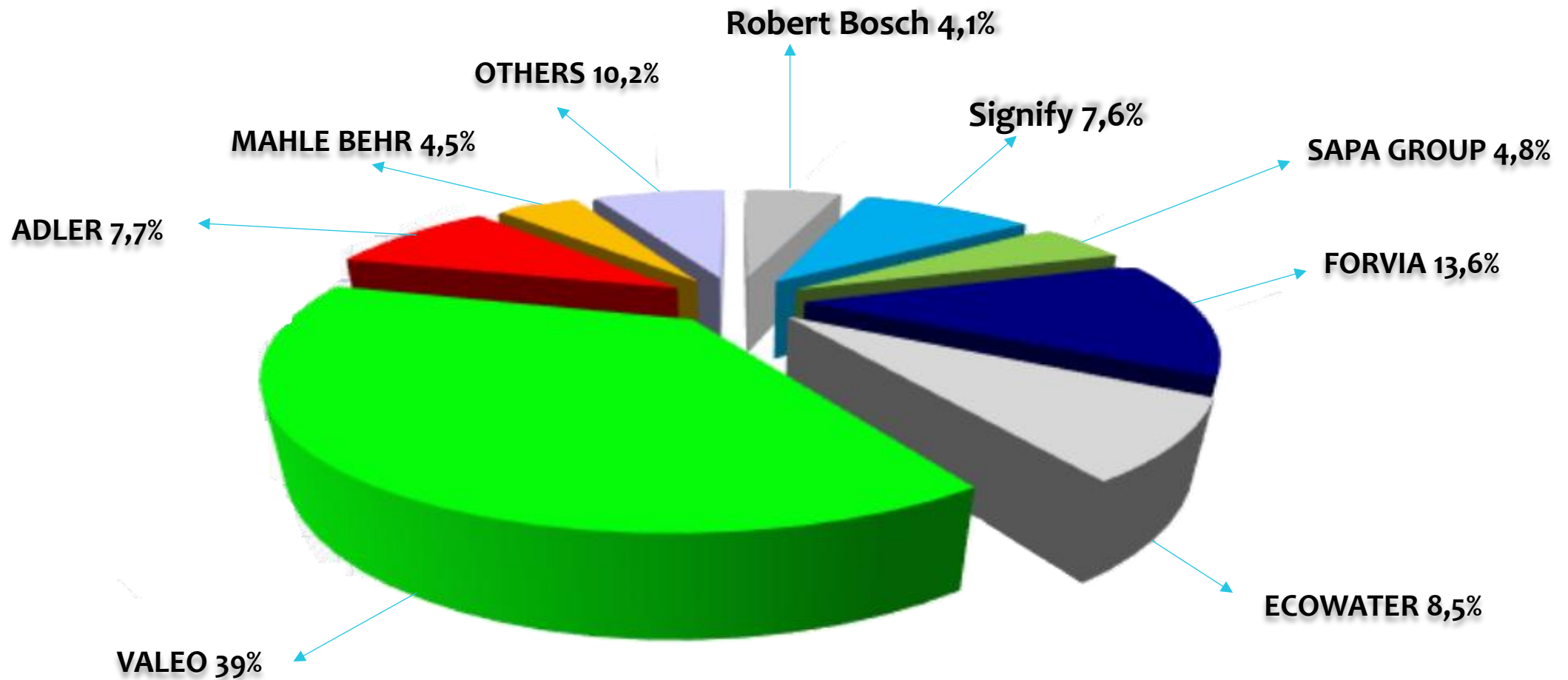

# TOTAL SALES

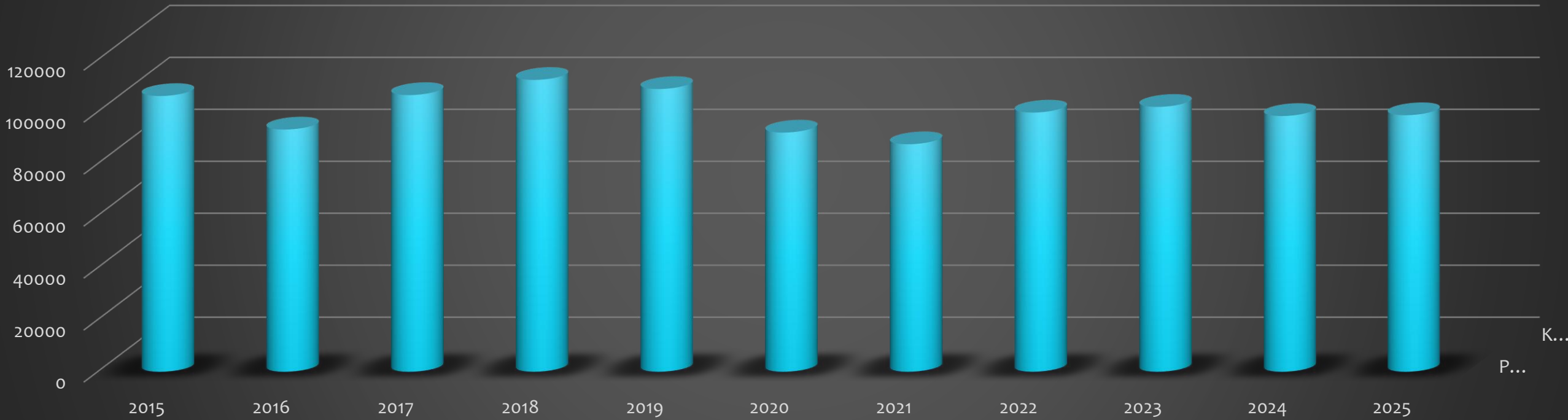

# Turntables for molds

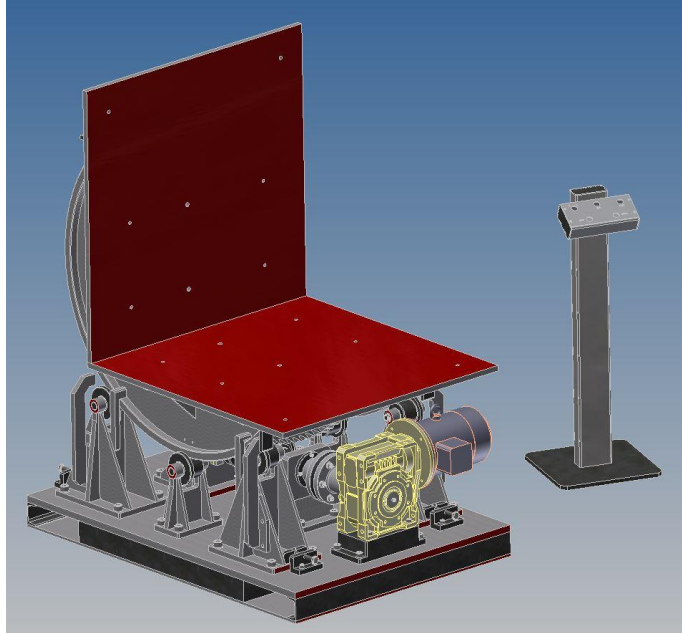

**Lifting capacity 8000 - 12 000 kg**

We offer turntables that facilitate the assembly and disassembly of large molds. We offer two sizes of the device:

1. For molds weighing up to 8 tons
2. For molds weighing up to 12 tons



# Thank You!

**GRAFORM** sp. z o.o.

+48 52 372 3914-0

graform@graform.pl

www.graform.pl

